Raspberry Pi Compute Module 5 IO Board

An application board for Raspberry Pi Compute Module 5.

Colophon

© 2024 Raspberry Pi Ltd

This documentation is licensed under a Creative Commons [Attribution-NoDerivatives 4.0 International](#) (CC BY-ND).

build-date: 2024-11-27

build-version: 6474ab9-clean

Legal disclaimer notice

TECHNICAL AND RELIABILITY DATA FOR RASPBERRY PI PRODUCTS (INCLUDING DATASHEETS) AS MODIFIED FROM TIME TO TIME ("RESOURCES") ARE PROVIDED BY RASPBERRY PI LTD ("RPL") "AS IS" AND ANY EXPRESS OR IMPLIED WARRANTIES, INCLUDING, BUT NOT LIMITED TO, THE IMPLIED WARRANTIES OF MERCHANTABILITY AND FITNESS FOR A PARTICULAR PURPOSE ARE DISCLAIMED. TO THE MAXIMUM EXTENT PERMITTED BY APPLICABLE LAW IN NO EVENT SHALL RPL BE LIABLE FOR ANY DIRECT, INDIRECT, INCIDENTAL, SPECIAL, EXEMPLARY, OR CONSEQUENTIAL DAMAGES (INCLUDING, BUT NOT LIMITED TO, PROCUREMENT OF SUBSTITUTE GOODS OR SERVICES; LOSS OF USE, DATA, OR PROFITS; OR BUSINESS INTERRUPTION) HOWEVER CAUSED AND ON ANY THEORY OF LIABILITY, WHETHER IN CONTRACT, STRICT LIABILITY, OR TORT (INCLUDING NEGLIGENCE OR OTHERWISE) ARISING IN ANY WAY OUT OF THE USE OF THE RESOURCES, EVEN IF ADVISED OF THE POSSIBILITY OF SUCH DAMAGE.

RPL reserves the right to make any enhancements, improvements, corrections or any other modifications to the RESOURCES or any products described in them at any time and without further notice.

The RESOURCES are intended for skilled users with suitable levels of design knowledge. Users are solely responsible for their selection and use of the RESOURCES and any application of the products described in them. User agrees to indemnify and hold RPL harmless against all liabilities, costs, damages or other losses arising out of their use of the RESOURCES.

RPL grants users permission to use the RESOURCES solely in conjunction with the Raspberry Pi products. All other use of the RESOURCES is prohibited. No licence is granted to any other RPL or other third party intellectual property right.

HIGH RISK ACTIVITIES. Raspberry Pi products are not designed, manufactured or intended for use in hazardous environments requiring fail safe performance, such as in the operation of nuclear facilities, aircraft navigation or communication systems, air traffic control, weapons systems or safety-critical applications (including life support systems and other medical devices), in which the failure of the products could lead directly to death, personal injury or severe physical or environmental damage ("High Risk Activities"). RPL specifically disclaims any express or implied warranty of fitness for High Risk Activities and accepts no liability for use or inclusions of Raspberry Pi products in High Risk Activities.

Raspberry Pi products are provided subject to RPL's [Standard Terms](#). RPL's provision of the RESOURCES does not expand or otherwise modify RPL's [Standard Terms](#) including but not limited to the disclaimers and warranties expressed in them.

Table of contents

Colophon	1
Legal disclaimer notice	1
1. Introduction	3
2. Features	4
2.1. CM5 module connectors	4
2.2. PSU input	4
2.3. Power Button	4
2.4. Dual full-size HDMI 2.0 connectors	5
2.5. Gigabit Ethernet RJ45	5
2.6. USB 3.0 Ports	5
2.7. USB Type C connector (Data)	5
2.8. microSD card socket	5
2.9. M.2 M-Key socket	5
2.10. Fan connector	6
2.11. MIPI Interface connectors (22-pin 0.5mm pitch cable)	6
2.12. Raspberry Pi HAT connector	6
2.13. Real time clock Battery	6
2.14. Jumpers	6
2.14.1. R4/R5 Vref voltage selection	6
2.14.2. J6 CSIO DSI0 I2C enable	6
2.15. LEDs	7
3. Mechanical diagram	8
4. Circuit diagram	9
Appendix A: Mean Time Between Failure (MTBF)	11
Documentation Release History	12
27 November 2024	12

Chapter 1. Introduction

Figure 1. Render of the Raspberry Pi Compute Module 5 IO Board.

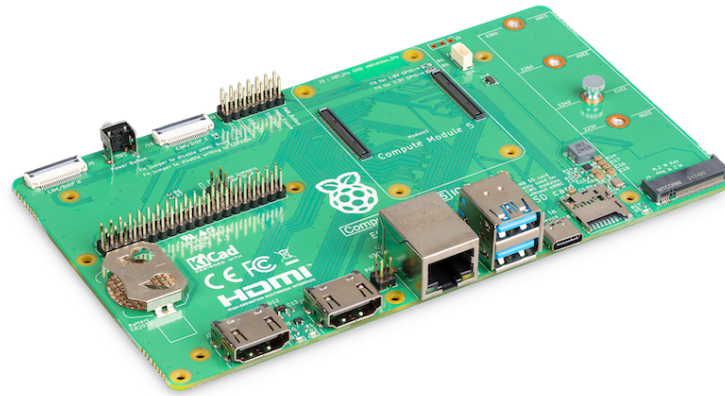

The Raspberry Pi Compute Module 5 IO Board (CM5IO) is designed to assist in the development of products that make use of Raspberry Pi Compute Module 5. The Raspberry Pi Compute Module 5 IO Board contains many of the interfaces that Raspberry Pi 5 has, and for general usage you should refer to the [Raspberry Pi 5 documentation](#). The CM5IO has been designed as both a reference design for CM5 or to be used directly as a product with the possible addition of M.2 M Key cards and Raspberry Pi HATs.

Chapter 2. Features

- Accepts the complete range of CM5 modules
- External +5v USB-C PSU
- Power button to wakeup and shutdown the CM5
- 2 × full-size HDMI 2.0 connectors
- Gigabit Ethernet RJ45 with PoE support
- 2 × USB 3 sockets
- microSD card socket for CM5Lite modules
- M.2 M key PCIe socket
- four-pin JST-SH PWM fan connector
- 2 × MIPI DSI/CSI-2 FPC connectors (22-pin 0.5mm pitch cable)
- HAT footprint with 40-pin GPIO connector
- PoE header
- RTC battery socket
- Jumpers to disable features such as eMMC boot, EEPROM write, the power button, and the USB OTG connection

2.1. CM5 module connectors

The two CM5 module connectors are positioned so the on-board wireless antenna is at the edge of the board for best wireless performance.

2.2. PSU input

The main PSU input ([J11](#)) is a standard USB-C connector. By default, the Raspberry Pi Compute Module 5 IO Board attempts to negotiate 5V @ 5A. You can power Raspberry Pi Compute Module 5 IO Board with a [standard Raspberry Pi 5 power supply](#). If the Raspberry Pi Compute Module 5 IO Board doesn't negotiate 5A, CM5 will display a warning; this can be disabled. The exact power consumption greatly depends on the processor load and peripherals plugged into Raspberry Pi Compute Module 5 IO Board.

If you want to supply an external +5V supply to the board, this can be done via [J8](#).

2.3. Power Button

The power button replicates the function of the button on the Raspberry Pi 5. A short press brings up the shutdown menu. Another press powers the system down. A long press forces the system to power down. A short press from a previously shutdown system boots the system.

2.4. Dual full-size HDMI 2.0 connectors

CM5 does most of the interfacing required for the HDMI interface so that most signals are directly connected to the CM5 board. HDMI connectors require a +5V supply, which is provided on the Raspberry Pi Compute Module 5 IO Board via a current-limited switch.

2.5. Gigabit Ethernet RJ45

The Raspberry Pi Compute Module 5 IO Board uses a standard 1:1 Ethernet magjack, which supports PoE as well. Additional ESD protection is provided on the Raspberry Pi Compute Module 5 IO Board, since this is typically needed for PoE applications. The PoE signals from the RJ45 connector are connected to **J9**. Typically, a PoE HAT supplies +5V to the Raspberry Pi Compute Module 5 IO Board.

2.6. USB 3.0 Ports

The Raspberry Pi Compute Module 5 IO Board has two USB 3.0 Ports.

There is an internal current limit switch to provide VBUS to the USB connectors. The current limit is set to approximately 1.6A.

2.7. USB Type C connector (Data)

The USB Type C (USB-C) connector enables Raspberry Pi Compute Module 5 IO Board updates via `rpiboot`. The USB-C port on the host computer must supply ample current to power the Raspberry Pi Compute Module 5 IO Board. If the computer isn't capable, use a powered USB hub.

2.8. microSD card socket

WARNING

For use only with CM5Lite modules.

The microSD card socket is a push-push socket. To release the microSD card, gently push on the card to unlock it.

2.9. M.2 M-Key socket

The M.2 M-Key slot is designed for standard M.2 M key cards. You should ensure that there is a suitable OS driver for your card. Typically this connector is used with NVMe drives.

By default, the PCIe port supports PCIe Gen 2 × 1 (5Gbps). PCIe Gen 3 × 1 (8Gbps) is possible, but experimental and therefore unsupported.

2.10. Fan connector

Raspberry Pi Compute Module 5 IO Board uses the same fan connector as the Raspberry Pi 5. As a result, you can use any fans that work with Raspberry Pi 5.

NOTE : If the Raspberry Pi Compute Module 5 is powered down the FAN will come on as the Fan PWM pin is not longer driven. If you are designing a board and this is undesirable then the Fan could instead be powered from the USB VBUS enable from U6 as when the Raspberry Pi Compute Module 5 is shutdown the VBUS_EN is pulled low and so VBUS is shutdown.

2.11. MIPI Interface connectors (22-pin 0.5mm pitch cable)

There are two 4-lane MIPI DSI/CSI-2 connectors. CAM/DISP 0 supports both displays or cameras. CAM/DISP 0 supports using a signal to power down the camera to save power. CAM/DISP 1 typically needs two jumpers fitting to J6 to route the I2C signals from the GPIO connector to the camera connector. CAM/DISP 1 can be used with displays and cameras. If it is used with a camera, it isn't possible to power down the camera.

2.12. Raspberry Pi HAT connector

The Raspberry Pi Compute Module 5 IO Board has a standard Raspberry Pi 40-way HAT connector. Mounting holes are also provided so that standard HATs may be used.

2.13. Real time clock Battery.

A battery socket is provided for a CR2032 battery. Batteries typically last for 5 years.

2.14. Jumpers

2.14.1. R4/R5 Vref voltage selection

By default the Raspberry Pi Compute Module 5 IO Board sets the CM5 IO voltage to +3.3V via R5. Moving R5 to R4 sets the IO voltage on CM5 to +1.8V. Moving the resistor requires the use of a soldering iron.

i NOTE

Only one of R4 or R5 may be fitted at any one time.

2.14.2. J6 CSI0 DSI0 I2C enable

i NOTE

For the J6 jumpers, if either CAM/DISP 1 is used then both jumpers must be fitted to route the I2C bus to the connectors.

Table 1. J2 jumpers

Pin	Function
1-2	nRPiBOOT - if fitted, forces USB booting (useful if the eMMC becomes corrupted)
3-4	EEPROM_nWP - if fitted, write-protects the EEPROM on CM5
6	SYNC_OUT - IEEE1588 timing pin. (can be configured as input)
12	PMIC_ENABLE
13-14	Connect a push button to wakeup or shutdown CM5.

Table 2. J3 (not fitted by default)

Pin	Function
1	WL_nDIS - when connected to ground the wireless interface will be disabled
2	GND - ground
3	BT_nDIS - when connected to ground the Bluetooth interface will be disabled

2.15. LEDs

Red LED

This LED duplicates the function of the red LED on Raspberry Pi 5.

Green LED

This LED duplicates the function of the green LED on Raspberry Pi 5.

Chapter 3. Mechanical diagram

Figure 2. Mechanical diagram of the Raspberry Pi Compute Module 5 IO Board.

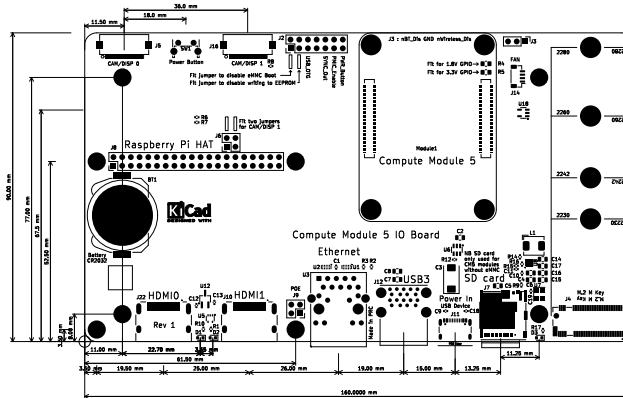

NOTE

For additional information see the [CM5 design files](#).

Chapter 4. Circuit diagram

Figure 3. Top level

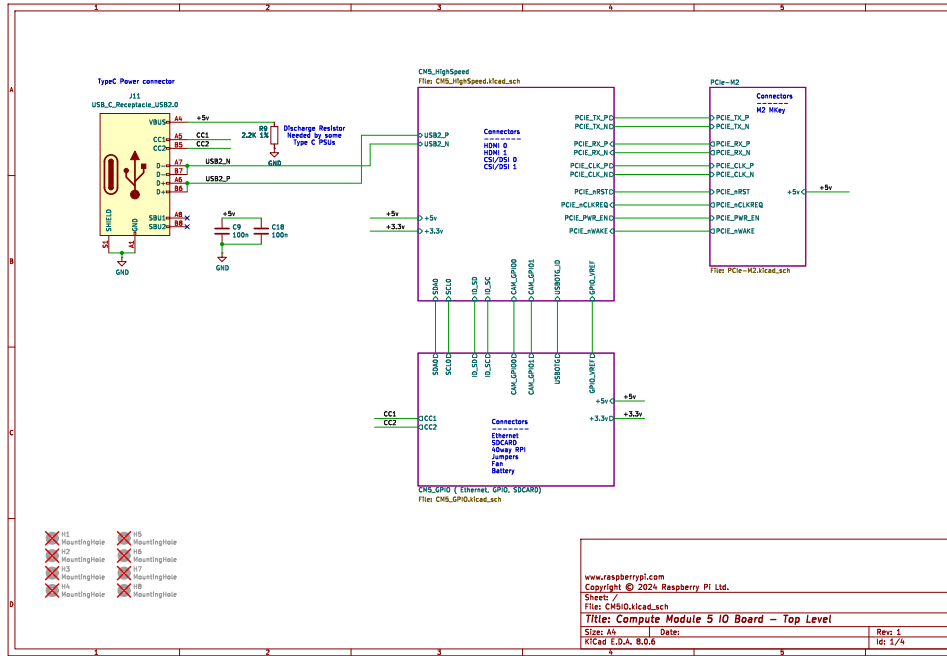

Figure 4. CM5 high speed

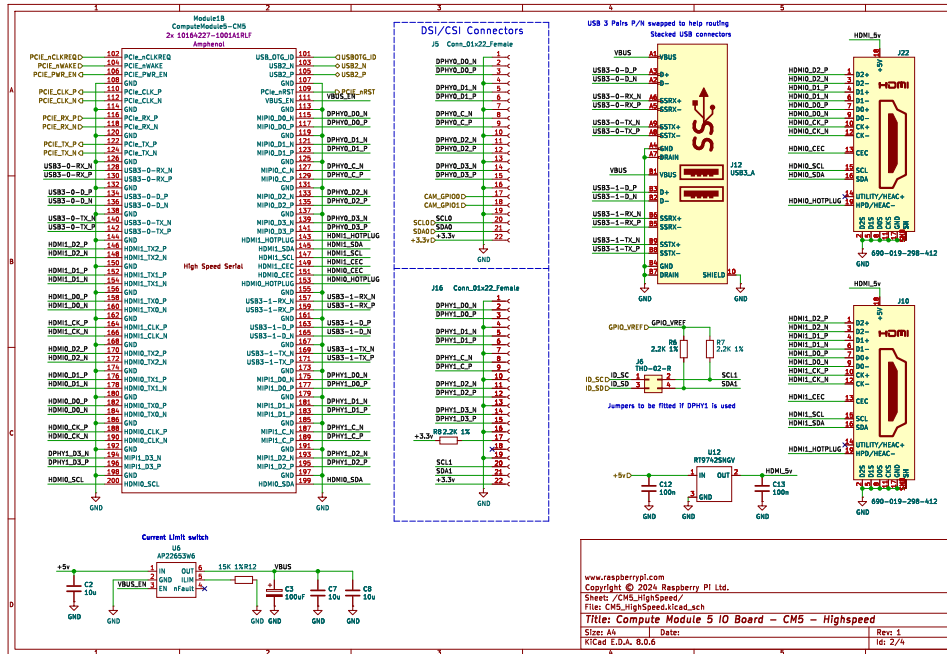

Figure 5. CM5 GPIO

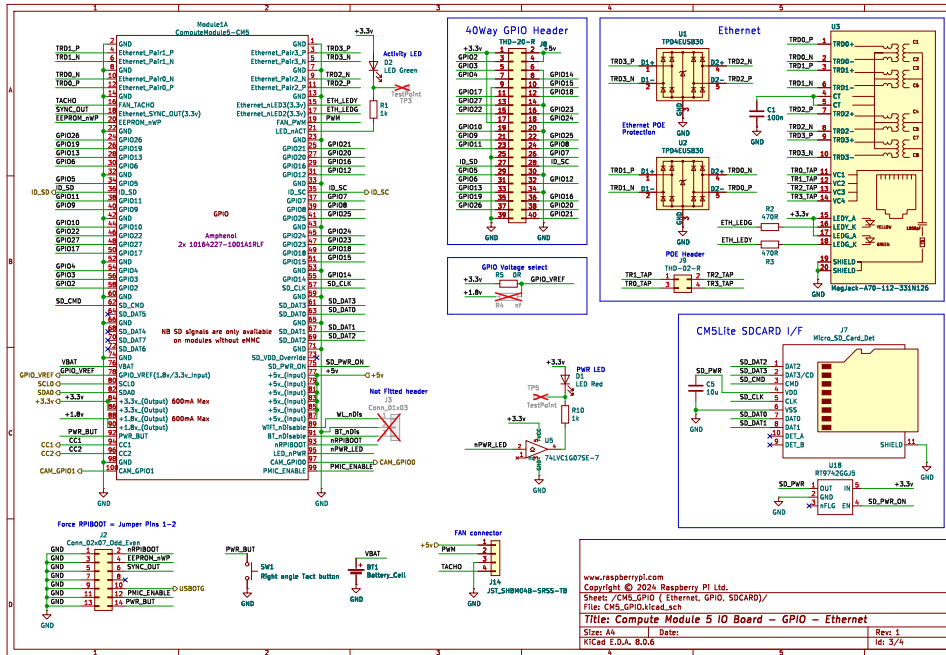
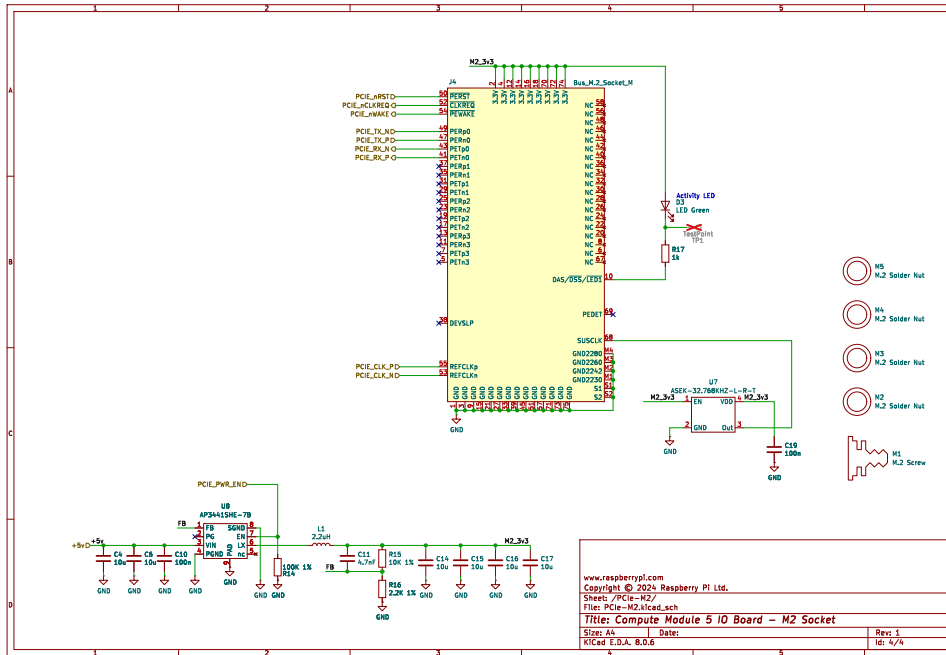

Figure 6. M.2 connector



Appendix A: Mean Time Between Failure (MTBF)

Table 3. Mean time between failure for Raspberry Pi Compute Module 5 IO Board

Model	Mean Time Between Failure Ground Benign (Hours)	Mean Time Between Failure Ground Mobile (Hours)
Raspberry Pi Compute Module 5 IO Board	131 000	15 000

Ground, benign

Applies to non-mobile, temperature and humidity controlled environments readily accessible to maintenance; includes laboratory instruments and test equipment, medical electronic equipment, business and scientific computer complexes.

Ground, mobile

Assumes levels of operational stress well above normal domestic or light industrial use, without temperature, humidity or vibration control: applies to equipment installed on wheeled or tracked vehicles and equipment manually transported; includes mobile and handheld communications equipment.

Documentation Release History

27 November 2024

- Initial release.



Raspberry Pi is a trademark of Raspberry Pi Ltd